



4 Little Brook Road
West Wareham, MA 02576
Tel: (508) 291-0960
Fax: (508) 291-0975
Email: sales@ore.com

Acoustic Cable Cutter and Transponder

OPERATING AND MAINTENANCE MANUAL

Acoustic Cable Cutter and Transponder

REV. A, February 5, 2009

Standard Commercial Warranty

All equipment manufactured by ORE Offshore is warranted against defective components and workmanship for repair at the plant in Wareham, Massachusetts, free of charge for a period of one year after shipment. Shipping costs are to be borne by the customer. Malfunction due to improper use is not covered in this warranty and ORE Offshore disclaims any liability for consequential damage resulting from defects in the performance of the equipment. No product is warranted as being fit for a particular purpose and there is no warranty of merchantability. This warranty applies only if: (i) the items are used solely under the operating conditions and in the manner recommended in Seller's instruction manual, specifications, or other literature; (ii) the items have not been misused or abused in any manner or repairs attempted thereon; (iii) written notice of the failure within the warranty period is forwarded to Seller and the directions received for properly identifying items returned under warranty are followed; and (iv) the return notice authorizes Seller to examine and disassemble returned products to the extent Seller deems necessary to ascertain the cause for failure. The warranties expressed herein are exclusive. There are no other warranties, either express or implied, beyond those set forth herein, and Seller does not assume any other obligation or liability in connection with the sale or use of said products. Any product or service repaired under this warranty shall be warranted for the unexpired portion of the original warranty period only.

Equipment not manufactured by ORE Offshore is supported only to the extent of the original manufacturer's warranties.

Return Procedure

It is necessary to obtain from ORE Offshore a Returned Material Evaluation (RME) number prior to returning equipment. This is to assist tracking and arrival recognition. Follow the procedure listed below when returning U.S. origin goods to prevent delays and additional costs on Returned American Goods.

New Import Procedure/Returned American Goods

1. All shipments must be accompanied by two copies of your commercial invoice showing value of material and any reason for return.

* Whenever possible, please send copies of original export shipping documents with the consignment.

2. If the value is over \$1,000.00, the following shipper's oath must be sent with the invoices. (This can be typed on the invoice or on a separate letterhead.)

"I, _____, declare that the articles herein specified are, the growth, produce, or manufacture of the United States; that they were exported from the United States; From the Port of _____, on or about _____; that they are returned without having been advanced in value or improved in condition by any process of manufacture or any other means, that no drawback, bounty, or allowance has been paid or admitted thereof.

Signed _____"

3. If more than one part per consignment, a packing list must also accompany the shipment. It is acceptable to combine the commercial invoice and packing list as long as the contents of each carton are clearly numbered and identified on the commercial invoice.
4. Consign all air freight shipments to ORE Offshore in care of Intercontinental Air Frt., Inc., Logan Int'l Airport, East Boston, Mass. 02128.
5. If the equipment is property of ORE Offshore please insure for full value.
6. Route via Logan International Airport only as the final destination.
7. Mail one invoice, packing list and copy of airway bill to ORE Offshore upon shipment.
8. Please refer to issued Returned Material Evaluation number on all documents and correspondence.
9. Air freight must be prepaid on all returns.

ORE Offshore
4 Little Brook Road
West Wareham, MA 02576
Tel: (508) 291-0960 Fax: (508) 291-0975
Email: sales@ore.com

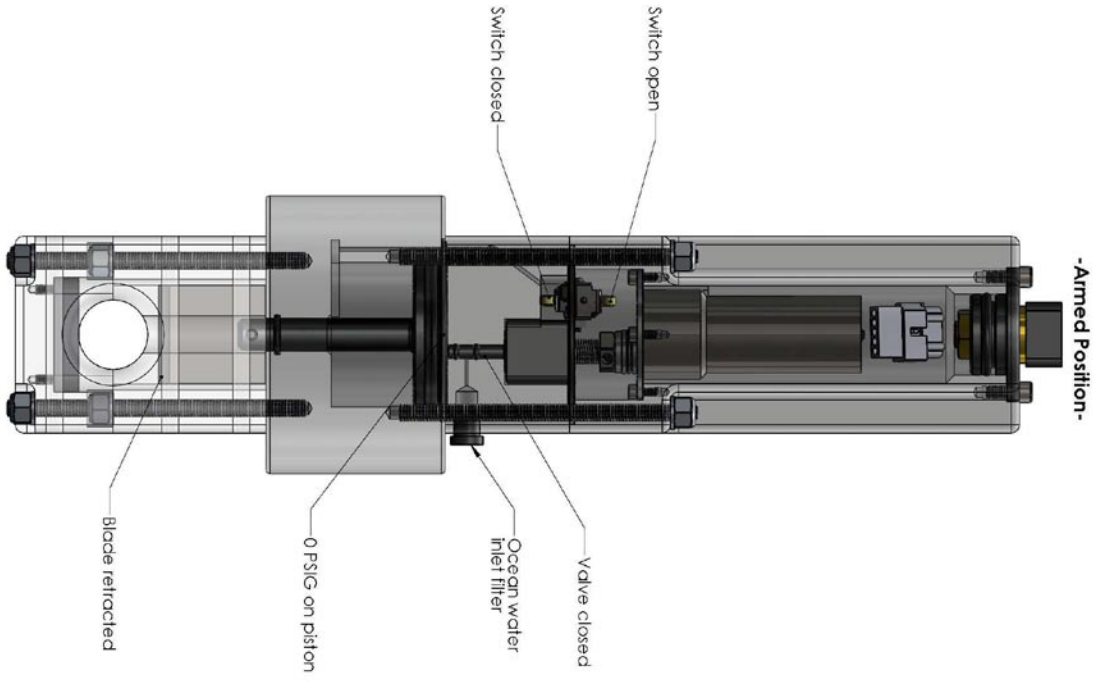

Top Assembly Acoustic Cable Cutter
Figure 1

TABLE OF CONTENTS

- 1. General Information**
 - 1.1 Introduction**
 - 1.2 Specifications**

- 2. Installation and Operation**
 - 2.1 Introduction**
 - 2.2. Housing and Release Preparation and Care:**

- 3. Cutter Function**
 - 3.1 Cutter Inspection**

- 4. ON/OFF Option**

- 5. Air Acoustic Tests**

- 6. Status Reply**

- 7. Battery Replacement**
 - 7.1 Battery replacement considerations.**

1. GENERAL INFORMATION

1.0 Introduction

This manual describes the ORE Offshore Acoustic Cable Cutter and Transponder. The ORE Offshore Acoustic Cable Cutter and Transponder utilizes ORE Offshore's Binary Acoustic Command System (BACS) and to operate requires either the Model 8011M, 8011A, Acoustic Command/Ranging Transceivers or the Model AMD200R Deck unit. The system can be used to sever most non-metallic tow cables or umbilical's when activated and acts as a transponder for recovery operations. In addition to these typical applications there are a number of specialized uses for this system.

The Binary Acoustic Command System (BACS) provides 12,000 possible command codes. The Cable cutter has an enable/disable command for controlling the transponder function as a standard feature. When disabled the transponder will not reply when interrogated. The "CUT" command causes the system to sever the cable that it running through it. The "CUT" command can be sent and will sever the cable whether the system is enabled or disabled. The "ARM" command closes the valve in the cable cutter. The "ARM" command is used when readying the system for use. The enable and disable function only controls the transponder section.

DANGER!!

Do not send the "ARM" command when deployed. If the "ARM" command is sent while at depth the system can hold whatever internal pressure is present.

DANGER!!

When the instrument has internal pressure, careless handling may endanger the user's hands. Exercise extreme caution to prevent serious personal injury.

1.2 Specifications

Instrument housing mechanical:

- Material - Borosilicate glass
- Diameter - 17"
- Weight in air - 57 lbs
- Buoyancy - 55 lbs
- Depth rating - 6700 meters

Release mechanism:

- Length - 19"
- Width (widest point) - 7.25"
- Weight in air - 41 lbs
- Weight in water - 33.5 lbs (estimated)
- Depth rating - 6000 meters
- *Cable length* - *4 meters*

Transducer:

- Element - piezoelectric ceramic, EC64
- Material - 316 Stainless steel, neoprene rubber, HDPE
- Cable length - 4 meters
- Weight in air - 7.5 lbs.

Electrical:

- Receiver sensitivity - 80dB re 1uPascal
- Reply source level - 190dB re 1uPascal @ 1 meter
- Command structure - BACS, tone pair 1
- Batteries - 2 each, ORE P/N B3217-002 welded alkaline packs
- Deployment life - 3 years
- Reply pings - 80,000
- Reply lockout period - 1 second

Electrical connections:

Two Impulse low profile, wet-plugable connectors

Transducer connection:

- Connector type - LPBH-3-FS
Pin designations:
 1. Shield and transducer base plate
 2. Transducer low
 3. Transducer High

Cutter connection:

- Connector type - LPBH-4-FS
Pin designations

Purge Port:

- Vitrovex, 316 stainless

Depth rating (working): 19600 ft. (6000 m.)

Weight in air: 12.5lb

Weight in water: 7.1lb

Wetted materials: 6061-T6 aluminum (hard coat anodized), 316 stainless steel, CPM-S90V stainless steel (cutting blade), delrin, nylon, brass (connector)

Minimum operating depth: 100m

Maximum operating depth: 6000m

Cutting force @100m: 450lb

Acoustic Specifications:

Commands:

Sensitivity: 80 dB re 1 uPa.

Signal to noise-spectrum-level ratio: ≥ 36 dB re root Hz.

Receiver type: Hard-limited (2000 Hz/330 Hz Bandwidths)

Coding:

General to 8000 series - Binary FSK

Allowed tone pairs (6)

Pair No.	“0”	“1”
1	9.5 kHz	9.9 kHz
2	9.5	10.3
3	9.5	10.7
4	9.9	10.3
5	9.9	10.7
6	10.3	10.7

Structure: Two successive 8 bit words with a 5 sec. interval between them. Each word comprised of 8 bits from a 16 bit command. The 16 bit command is a 15, 11 block cyclic code with an overall parity bit appended to the end to form a 16, 11 code with a minimum Hamming distance of 4 bits. Additionally, two transitions are required within each word, and no repetitions of words are allowed in a command.

Pulse width: 22 mSec.
Period: 250 mSec.
Total Command Time: 9 Sec.
Total lock out time: 14 Sec. re beginning
Total command capacity per tone pair: 2000
12000 commands for the 6 tone pairs.
Standard Command Functions:
CUT
ARM
Disable Transponder
Enable Transponder

Transponder:

Sensitivity - 80 dB re 1 uPa.
Signal to noise-spectrum-level ratio: ≥ 44 dB re root Hz for jitter
< ± 0.5 mSec. (3 Sigman). Jitter = ± 0.1 mSec. for noise-free
field.
Interrogate frequency: 9 or 11 kHz (Standard)
Post-filter bandwidth: 330 Hz.
Minimum pulse width: 5 mSec.
Reply frequency: Default 12 kHz (switch selectable)
Reply source level: 190 dB re 1 uPa. @ 1 m.
Reply pulse width: 10 mSec
Turnaround time delay: 12.5 mSec standard.
Lockout time: 1.0 Sec.

Environmental:

Temperature operating: -10 deg. C to +40 deg. C.
storage: -20 deg. C to +85 deg. C.

2. INSTALLATION AND OPERATION

DANGER!!

Do not send the “ARM” command when deployed. If the “ARM” command is sent while at depth the system can hold whatever internal pressure is present.

DANGER!!

When the instrument has internal pressure, careless handling may endanger the user’s hands. Exercise extreme caution to prevent serious personal injury.

2.1 Introduction:

This section contains the information relative to the basic set up and operation of the Acoustic Cable Cutter and Transponder. The user is referred to the specific information sheet that shipped with the unit, for details of his specific equipment. This sheet includes commands, and transponder frequencies for the particular release.

2.2. Cable Cutter Preparation and Care:

Disassembly Procedure:

DISASSEMBLY:

Figure 2. Disassembly.

CAUTION:

The ends and bore of the housing are O-ring seating surfaces. They must be protected while the unit is disassembled. Any scratches will impair the performance of the O-rings and may result in leaks.

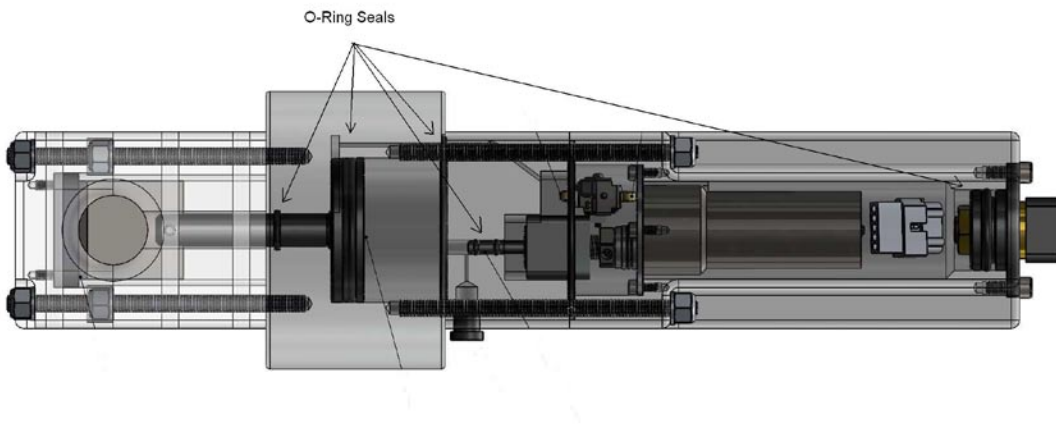

Figure 3.

Assembly:**Cable Cutter Assembly:**

Prepare the sealing surfaces for assembly by cleaning with a lint-free towel or swab, moistened if needed with alcohol. Inspect for scratches or nicks which will impair the O-ring efficiency. Apply a Very light coat of O-ring lubricant (i.e., Dow Corning 4 Compound) to the piston surface to aid sliding insertion of the piston seal. Inspect the O-rings for damage or manufacturing flaws such as tears, dimples or inclusions in the rubber. Lightly coat the O-rings with O-ring lubricant.

CAUTION:

Do not pinch or damage wires when inserting assembly into the housing.

Arming the Instrument:

The Cable Cutter is easily armed using only the acoustic deck unit that is provided with the system.

The instrument is easily armed by:

3.0 Cutting Function:

After the command to Cut has been decoded, the power supply is switched on to the motor. The threaded shaft is turned by the motor. The threaded shaft pulls the valve plunger assembly. When the valve plungers lower o-ring passes the inlet for the external pressure the pressure is allowed to enter the cylinder. The pressure in the cylinder pushes the blade against the cable. The maximum cutting force is defined by the external pressure available. See the graph below.

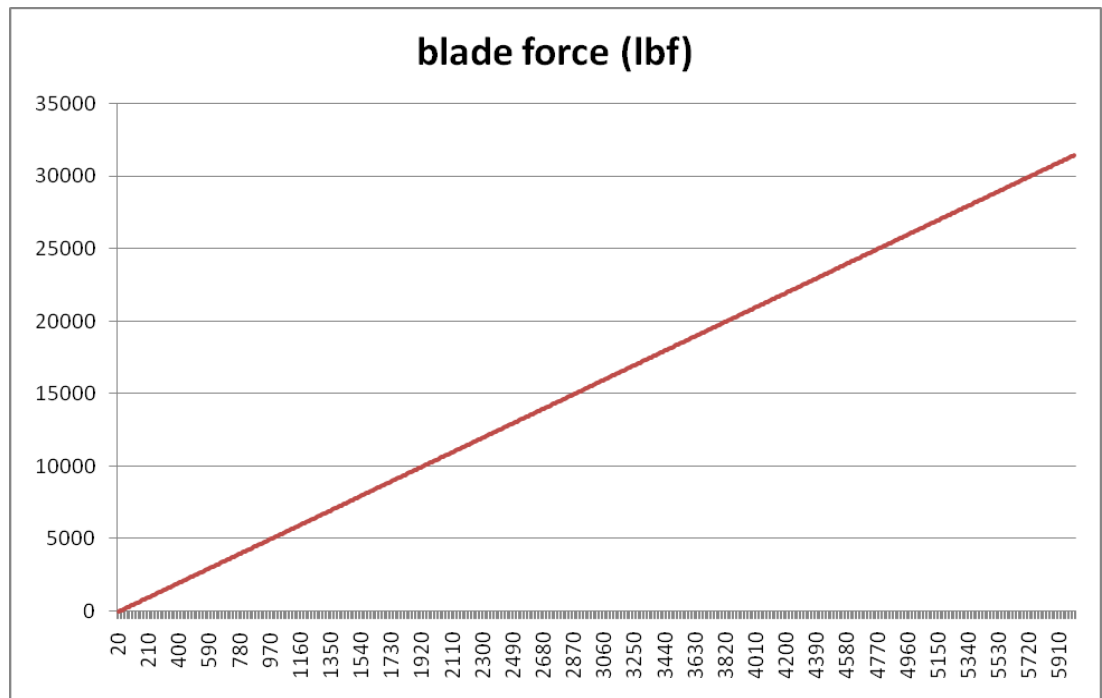

5. Air Acoustic Tests.

Always perform an air acoustic test of the commands and interrogate the instrument after assembling to assure proper working order. Every time the instrument is powered up, repeat the air acoustic test to assure proper operation. Place the speaker or transducer 1 meter of the underwater unit transducer when sending commands in air. The position of the transducers relative to one another may need to be adjusted to allow commands to get through in air. Ranges will not be accurate in air; these systems are designed to operate in water. The speed of sound in air can cause errors in command decoding and prevents accurate ranging however the systems can be tested in air. Test all functions of the system by sending each command and verifying that the state changed according to the command including status reply. If the mechanical cutter parts included the blade are to be tested pressure must be applied to the pressure inlet. This can be

accomplished with a hand hydraulic pump connected to the inlet. When this test is performed the blade will need to be pushed back into the armed position before the ARM command is sent. After the ARM command is sent and the valve has closed pressure should be applied to the inlet and the blade should not move. This test is to verify that the valve has closed and is sealed.

6. Status Reply

Upon receiving a valid command the instrument will return a series of pings which are an indication of the status of the tilt and the Armed or Cut position sense switches. The 4 possible status replies are:

Upright and armed: 15 pings at a 2 second rate.

Tilted and armed: 7 pings at a 2 second rate.

Upright and cut: 15 pings at a 1 second rate.

Tilted and cut: 7 pings at a 1 second rate.

7. Battery Replacement:

Unless the user has extensive experience sealing glass spheres it is recommended that the system is sent back to ORE Offshore for battery replacement.

7.1 Battery replacement considerations.

These systems are high performance instruments and it is presumed that they are employed to recover high value instruments and data. For this reason extreme care must be exercised in choosing replacement batteries. ORE Offshore makes considerable effort to test various batteries and to provide control of the manufacture of replacement batteries for its equipment. The user should exercise extreme care in selecting replacement battery packs. The particular manufacturer's cell discharge characteristics and repeatability should be known. The date of manufacture and the history of shipping and storage should be known if not controlled; batteries should be no more than one year old when placed in service. Cleanliness and careful inspection techniques should be employed when assembling the batteries into welded packs. Careful attention should be paid to purging the unit so as not to leave air or moisture inside before storage or deployment.